

# PRODUCT DATA SHEET

BIA-AUTOSUB • 810335



BRAND

**BIANCO  
PUMPZ**

## PRODUCT DETAILS

The Bianco AUTOSUB Submersible Pump is specially designed and manufactured for the rainwater industry.

Being a submersible design means that the pump can be placed inside the rainwater tank for a neat, secure and quiet installation.

It is intended for use in household applications for the automatic supply of clean water which contains no fibres.

## APPLICATIONS

- Household water supply
- Drinking water
- Gardening

## FEATURES

- Compact
- Easy to install and use
- Automatic on/off
- Intelligent controller
- Dry-run protection
- Water cooled motor

## TECHNICAL DATA

RATED POWER (W)	750
MAX. FLOW [LPM]	100
MAX. FLOW [M3/H]	6
MAX. HEAD [M]	45
MOTOR PROTECTION LEVEL	Class F
PROTECTION CLASS	IPX8
WORKING TEMPERATURE	-5°-40°C
LIQUID TEMPERATURE	0°C-35°C
MAX. DIVING DEPTH	7m
MAX. DIA. OF PARTICLE	1mm
MOTOR	Heavy Copper winding

RATED VOLTAGE	220V-240V
RATED CURRENT	5.3A @ 230V
POWER CABLE TYPE	H07RN-F
LENGTH OF POWER CABLE	10m
PROTECTION CLASS	IPX8
IMPELLERS	4
OUTLET	1" BSPF
PACKAGE DIMENSION	350x240x540mm
GROSS WEIGHT (KG)	12kg
AUTOMATION FUNCTION	iSENSOR Auto Control + Fixed Arm Float Switch
CUT IN PRESSURE	2.5 bar

## CURVE

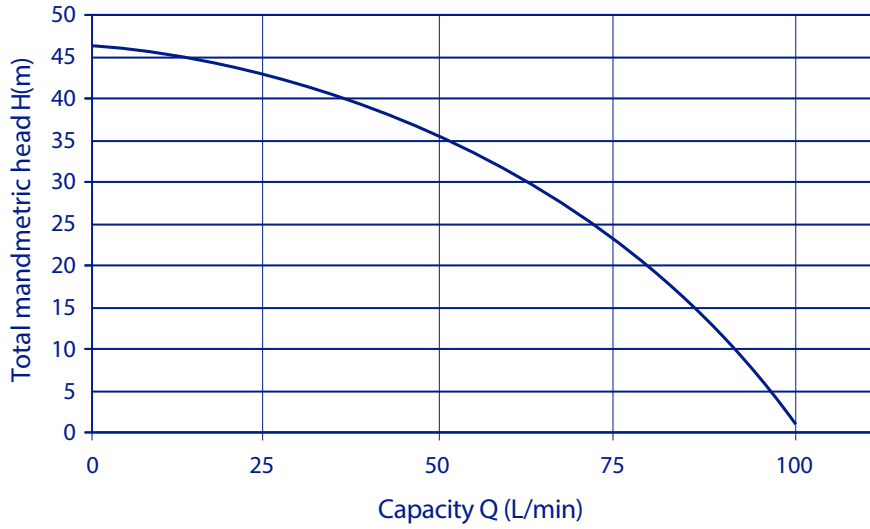

BIA-AUTOSUB & BIA-AUTOSUBX

## DIMENSIONS

**DIMENSIONS (mm)**

251 x 492

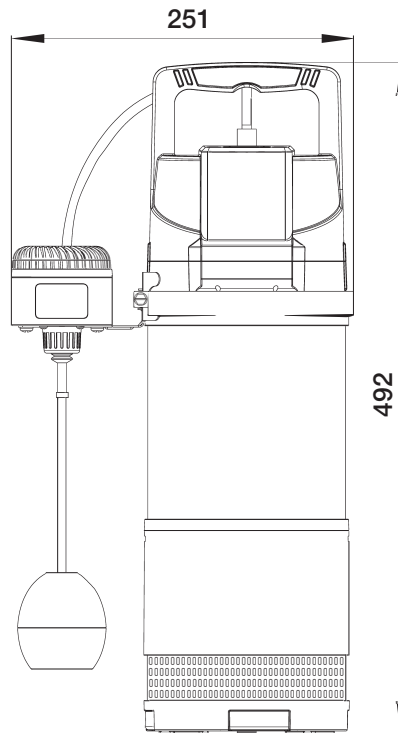

**DIAMETER (mm)**

159

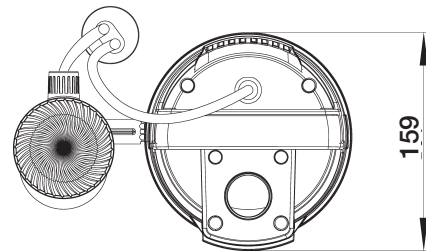

## WARRANTY / CERTIFICATIONS

